

25
VOLUMEN



foto**STIL**fondo.





fotoSTILfondo.



fotoSTILfondo.

SOLUCIONES PROFESIONALES

VOLUMEN 25

Con más de 25 años al servicio del Profesional de la Fotografía presentamos el nuevo catálogo volumen 25. Un catálogo pensado por y para el fotógrafo, con una amplia variedad de fondos, decorados y atrezzo que harán más atractivas tus fotografías.

Este año hemos actualizado nuestra página web www.fotostilfondo.com donde podrá hacer sus pedidos durante las 24h del día con todas las comodidades y servicios a su disposición.

Tan solo tiene que registrarse para acceder a ver todos los precios y realizar su compra.

Cómodamente la recibirá en su casa en un corto espacio de tiempo. Además si lo desea, le mantendremos informado de los nuevos productos, cursos de formación, consejos técnicos y ofertas que ofrecemos de forma periódica.

With over 25 years at the Professional Photographer service, we introduce a New Catalogue, Volume 25. A catalogue designed by and for the Photographer, with a wide variety of backgrounds, props and sets that will make your photographs more attractive.

This year we have updated our website www.fotostilfondo.com where you can place orders 24hours a day with all the amenities and services at your disposal.

You only need to register to see all the prices and make your purchase. You will receive the products at home in a short space of time. Also if you wish, we will keep you informed of new products, training courses, technical tips and sales we offer regularly.

MEDIDAS / Sizes / Grössen / Mesures

Serie 3D

Cm
120x200

Serie 200

LIENZO / Canvas

Cm	Feet
150x200	5'x6'5"
150x300	5'x9'8"
205x360	6'7"x11'8"
205x500	6'7"x11'8"
270x360	8'9"x11'8"
270x500	8'9"x16'4"
300x500	9'8"x16'4"
300x600	9'8"x19'6"

TELA / Muslin

Cm	Feet
150x200	5'x6'5"
150x300	5'x9'8"
205x360	6'7"x16'4"
205x500	6'7"x11'8"
270x360	8'9"x11'8"
270x500	8'9"x16'4"
300x500	9'8"x16'4"
300x600	9'8"x19'6"

Serie 400

LIENZO / Canvas

Cm	Feet
150x200	5'x6'5"
150x300	5'x9'8"
205x360	6'7"x16'4"
205x500	6'7"x11'8"
270x360	8'9"x11'8"
270x500	8'9"x16'4"
300x500	9'8"x16'4"
300x600	9'8"x19'6"

TELA / Muslin

Cm	Feet
150x200	5'x6'5"
150x300	5'x9'8"
205x360	6'7"x16'4"
205x500	6'7"x11'8"
270x360	8'9"x11'8"
270x500	8'9"x16'4"
300x500	9'8"x16'4"
300x600	9'8"x19'6"

Serie 1600

LIENZO / Canvas

Cm
150x200
150x300
205x360
205x500
270x360
270x500
300x500
300x600

Feet

5'x6'5"
5'x9'8"
6'7"x16'4"
6'7"x11'8"
8'9"x11'8"
8'9"x16'4"
9'8"x16'4"
9'8"x19'6"

Serie 7000

LIENZO / Canvas

Cm
150x200
150x300
260x360
260x500
260x600

Feet

5'x5'
5'x9,8'
8,5'x11,8'
8,5'x16,4'
8,5'x19,6'

● **MATERIALES / Materials**



Artículo fabricado en poliestireno endurecido con resina autoextinguible de alta densidad
Made of self-extinguishing polystyrene polyethylene toughened of high density



Artículo fabricado en madera
Made of wood



Artículo fabricado en hierro
Made of iron



Artículo fabricado en espuma
Made of sponge

● **SIMBOLOGIA / Symbology**



Imagen retocada digitalmente
Digitally retouched image

● **FOTÓGRAFOS / Photographers**

Fotógrafos Pepe Carrillo y Rosa M^a García
(Niclas) © 2014

● **MODELOS / Models**

Agradecemos la colaboración a los modelos:
Luz, Guillem, Joan, Bernat, Pau, Celia, Natalia,
Jordi, Pablo, Mateo, Paloma, Pascual, Guillem,
Rosa y Ana.

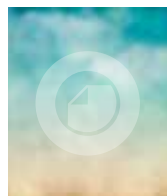

Ref: 7006



Ref: 1161



Ref: DF092



Ref: 7030



Ref: 7014



Ref: DF095



Ref: 1205



Ref: 1224

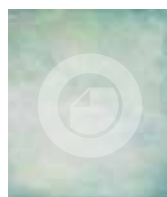

Ref: 7016



Ref: 7014



Ref: M3



serie7000



Ref: 1158

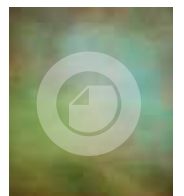

Ref: 7005



Ref: 7030



Ref: DF092



Ref: 1160



Ref: M1200



Ref: 1174



Ref: 7005



Ref: 1159



Ref: DF082



Ref: DF091



Ref: 7013



Ref: 7014



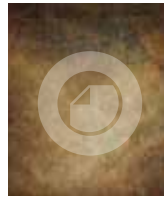

Ref: 7037



Ref: 1160

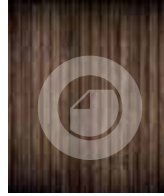

Ref: 7028



Ref: 1189



Ref: M1



Ref: 1190

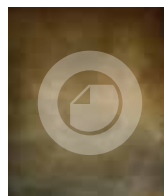

Ref: 7024



Ref: 1155



Ref: DF089 Pack de 3

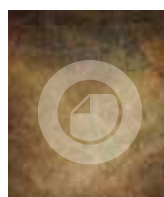

Ref: 7037



Ref: 1182

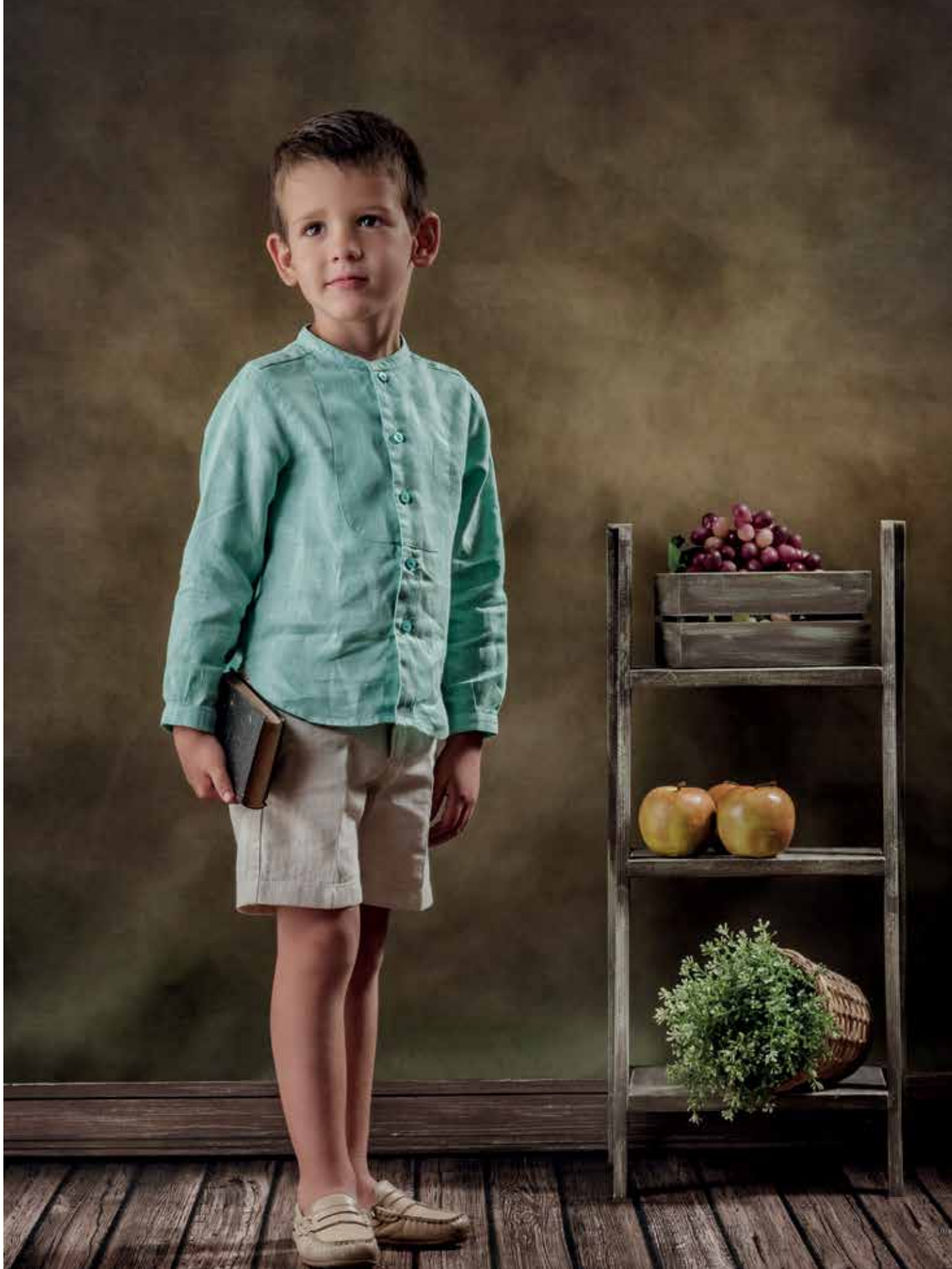

● Ref: M1199



Ref: 7024



Ref: 7028



Ref: M1

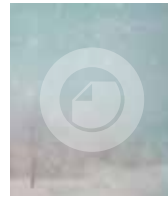

Ref: 7011



Ref: 7086



Ref: 1224



Ref: 7031



Ref: 7086



Ref: 7030



Ref: 1157



Ref: 7011



Ref: 7086

serie7000



Ref: M3



Ref: A1211



Ref: 7080



Ref: 7014



Ref: 7014



Ref: 1104



Ref: 7079



Ref: M3



Ref: DF087



Ref: 1196



Ref: B1201



Ref: M3



Ref: 7078



Ref: 7014



Ref: DF095



Ref: 1219



Ref: M3



Ref: 7012



Ref: 7014





Ref: M3



Ref: 1217



Ref: 7022



Ref: 7014



Ref: B1202



Ref: M3



Ref: B1200



Ref: 7021



Ref: 7014



Ref: M3



Ref: 7077



Ref: 7014



Ref: M3



Ref: B1201



Ref: 7045



Ref: 7014

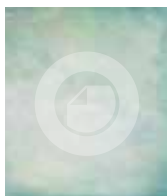

Ref: 7016



Ref: 7014



Ref: M3



● Ref: 1176



● Ref: 1216



Ref: 1198

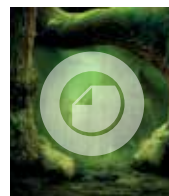

Ref: 7096



Ref: 7028

serie7000



Ref: 7077



Ref: 7078

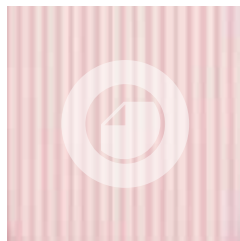

Ref: 7089



Ref: 7080



Ref: 7081

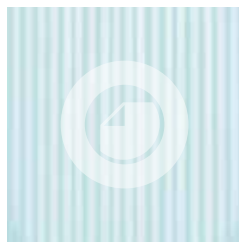

Ref: 7012



Ref: 7021

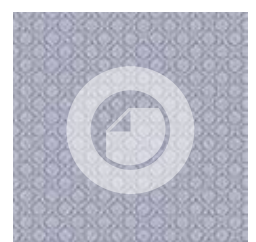

Ref: 7022

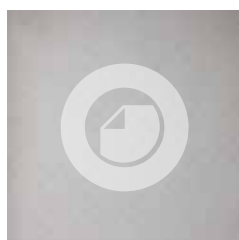

Ref: 7116

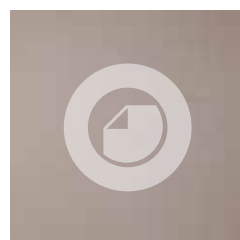

Ref: 7115

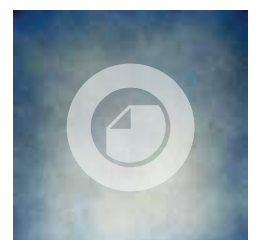

Ref: 7017



Ref: 7088

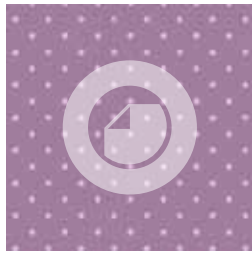

Ref: 7085

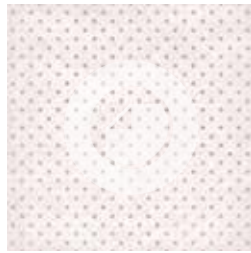

Ref: 7083



Ref: 7013

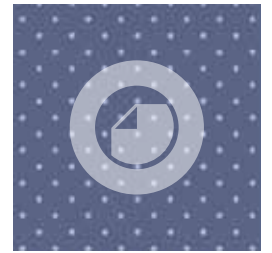

Ref: 7084



Ref: 7090

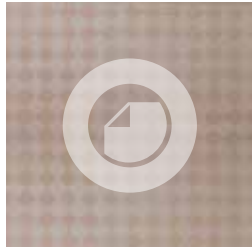

Ref: 7117



Ref: 7045

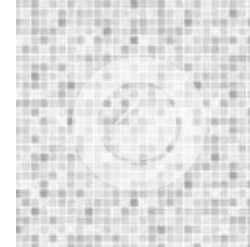

Ref: 7082



Ref: 7079



Ref: 7094

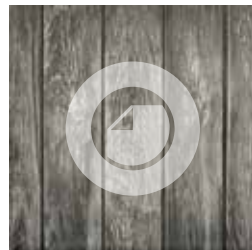

Ref: 7092

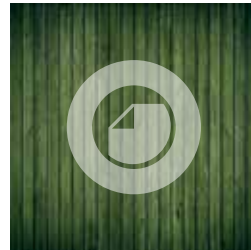

Ref: 7043



Ref: M1

Ref: M2

Ref: M3



Ref: 7091



Ref: 7040

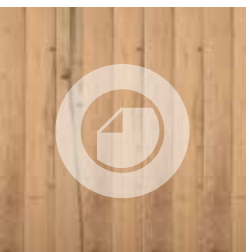

Ref: 7112



Ref: 7093

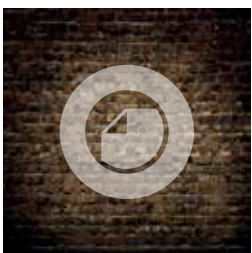

Ref: 7010



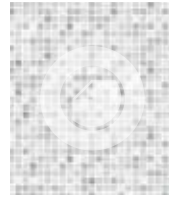

Ref: 7082



Ref: M3



● Ref: B1199



● Ref: 1178



● Ref: 1192



Ref: 7083



Ref: 7094



Ref: M3



Ref: 7086



● Ref: 1156



● Ref: 1195



Ref: DF034



Ref: DF084



Pack 3 sábanas
de cuna encaje
Ref: DF054



Ref: 7081



Ref: 7014



Ref: M3



Ref: M1



Ref: V1153



Ref: 7099



Ref: 7028



Ref: M628



Ref: 7095

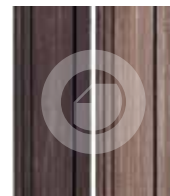

Ref: M1



Ref: DF096



Ref: 1225



Ref: 7087



Ref: 7028



Ref: M1



Ref: 1162



Ref: DF092



Ref: 7098



Ref: 7014



Ref: 1189



Ref: 1190

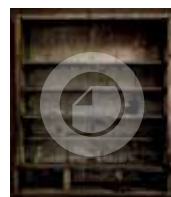

Ref: 7023

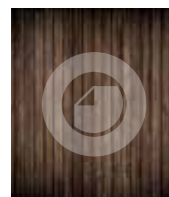

Ref: 7028



Ref: DF086



Ref: 1197



Ref: B1201



Pack 3 sábanas
de cuna encaje
Ref: DF054



Ref: 7089



Ref: M3



Ref: 7014

serie7000



Ref: 1187



Ref: DF085



Ref: 7024



Ref: DF094



Ref: 7018



Ref: 7014



Ref: M3



Ref: 1218



Modelo: 1044



Ref: 1155



Ref: DF096

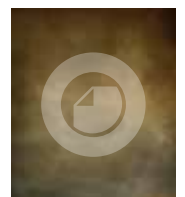

Ref: 7024



Ref: 7007



Ref: 7008



Ref: 7009



Ref: 7095



Ref: 7096



Ref: 7024



Ref: 7099



Ref: 7023

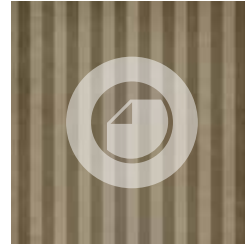

Ref: 7018



Ref: 7087



Ref: 7097



Ref: 7100

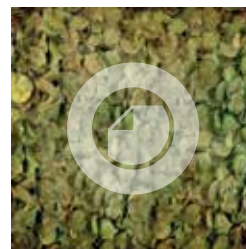

Ref: 7111



Ref: 7047

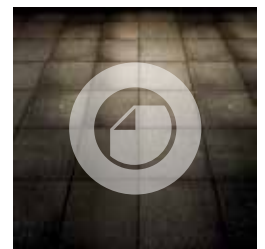

Ref: 7019



Ref: 7015

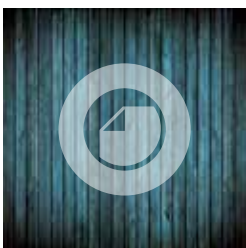

Ref: 7027

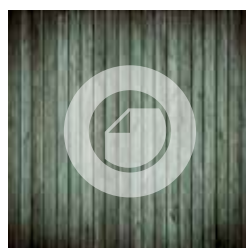

Ref: 7041

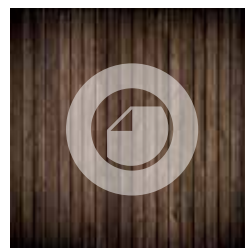

Ref: 7028

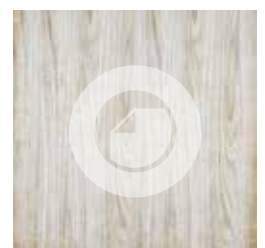

Ref: 7014



Ref: 7006



Ref: 7030

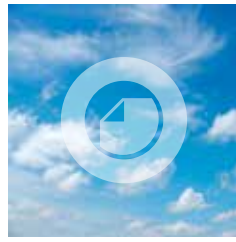

Ref: 7098



Ref: 7011



Ref: 7086



Ref: 7031

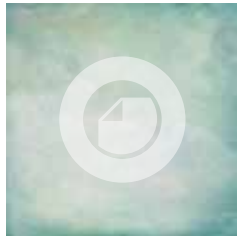

Ref: 7016



Ref: 7002



Ref: 7046



Ref: 7000



Ref: 7004

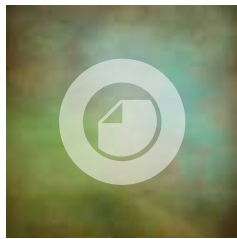

Ref: 7005



Ref: 7001

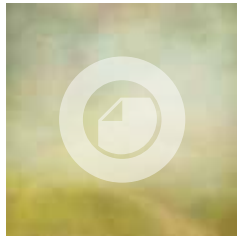

Ref: 7003







Ref: 7035



Ref: 7025

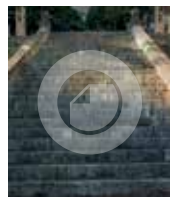

Ref: 7062



Ref: 1498



Ref: 7051

serie7000



Ref: 7101



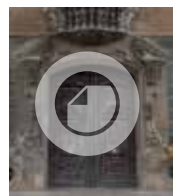

Ref: 7104

serie7000



Ref: 7010



Ref: 7037



Ref: M1



Ref: 1189



Ref: 7064



Ref: 1164



Ref: 1172

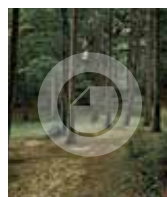

Ref: 7026



Ref: M1210



Ref: 628



Ref: 7059



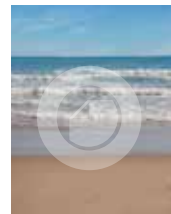

Ref: 7036



Ref: 1204

serie7000



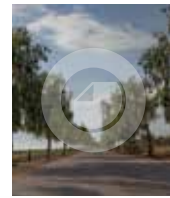

Ref: 7054



Ref: 7065





Ref: 1154



Ref: 7054

serie7000





Ref: 1221



Ref: 7058

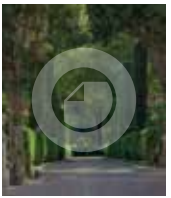

Ref: 7057



Ref: 7026



Ref: 1210



Ref: 1163

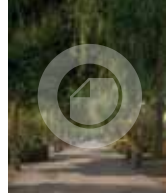

Ref: 7056



Ref: 1173



Ref: 1170



Ref: 7068



Ref: V1210



Ref: 7029



serie7000



Ref: R1210



Ref: 7057





Ref: 7071



Ref: 1227



Ref: 7060



Ref: 7069

serie**7000**



Ref: 7104



Ref: 1170



Ref: 1167



Ref: 1171



Ref: 1168



Ref: 1172



Ref: 1169



Ref: 7071



Ref: 1163



Ref: 1154



Ref: 7102

serie7000



Ref: 7020

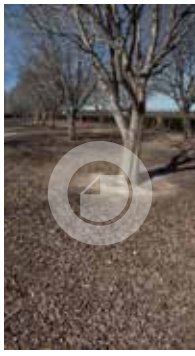

Ref: 7025



Ref: 7026

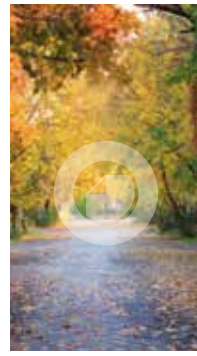

Ref: 7029

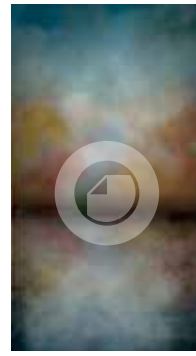

Ref: 7032



Ref: 7033

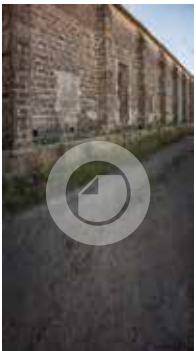

Ref: 7034



Ref: 7035

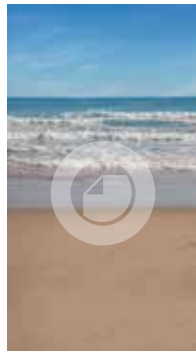

Ref: 7036

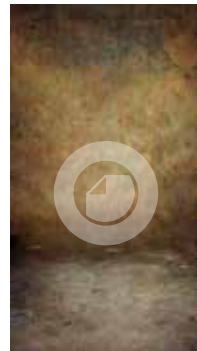

Ref: 7037

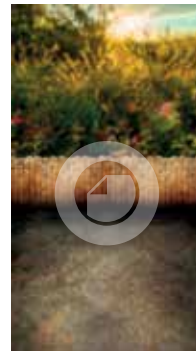

Ref: 7038

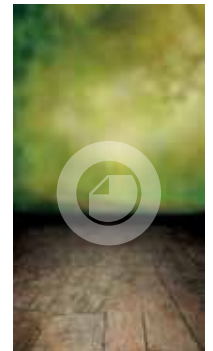

Ref: 7039



foto**STILL**fondo.

serie**7000**

fondos**7000**



Ref: 7044



Ref: 7051



Ref: 7054

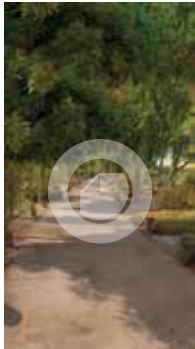

Ref: 7055



Ref: 7056



Ref: 7057



Ref: 7058

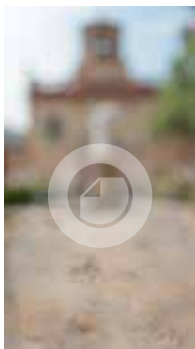

Ref: 7059



Ref: 7060



Ref: 7061



Ref: 7062



Ref: 7063



Ref: 7064



Ref: 7065

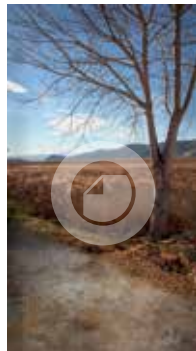

Ref: 7066

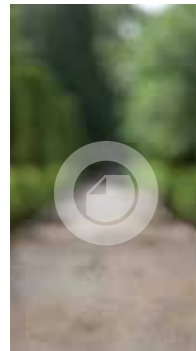

Ref: 7067



Ref: 7068



Ref: 7069

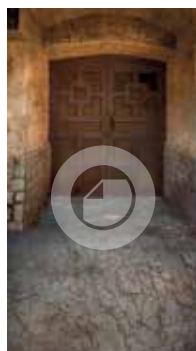

Ref: 7070



Ref: 7071



Ref: 7072



Ref: 7073



Ref: 7074



Ref: 7076

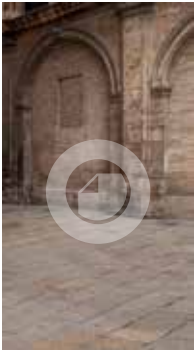

Ref: 7101

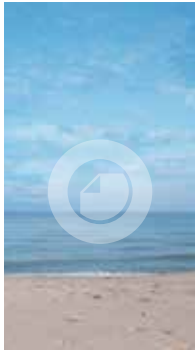

Ref: 7102



Ref: 7103



Ref: 7104



Ref: 7105

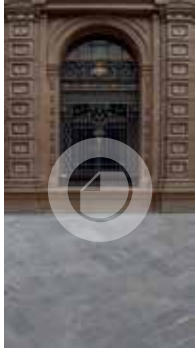

Ref: 7106



Ref: 7107



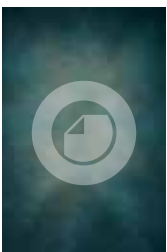

Ref: S204



Ref: 1215

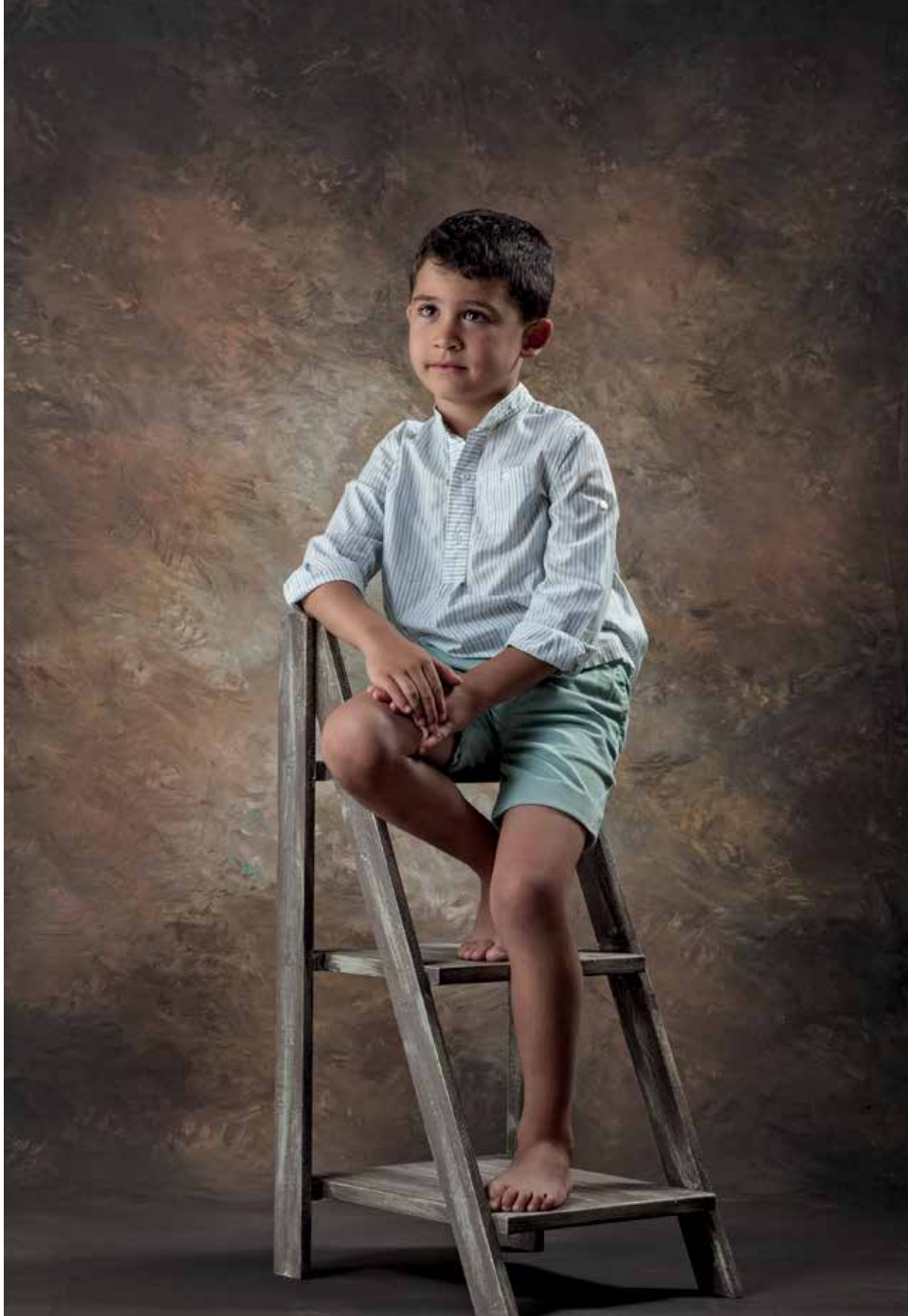

Ref: M1199

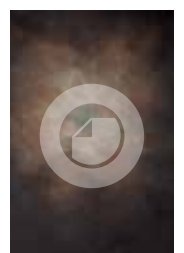

Ref: S205

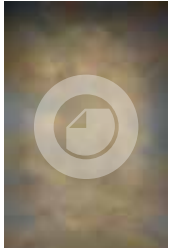

Ref: S206

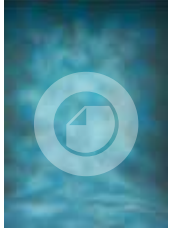

Ref: S207





Ref: S208

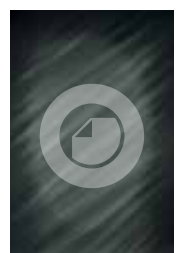

Ref: S209



Ref: S401



Ref: 1165



Ref: B1202



Ref: 1165

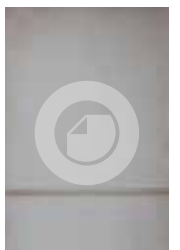

Ref: S402



Ref: S407



Ref: S408





serie200



Ref: S201



Ref: S202

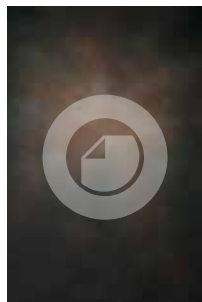

Ref: S203

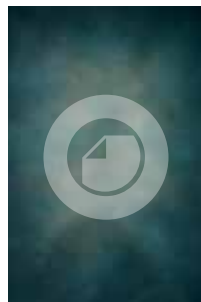

Ref: S204

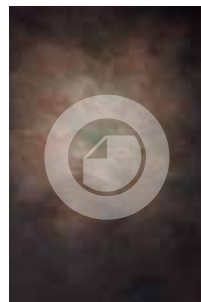

Ref: S205

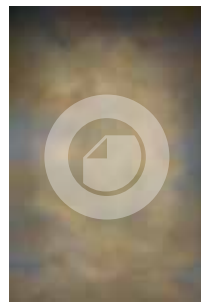

Ref: S206



Ref: S207

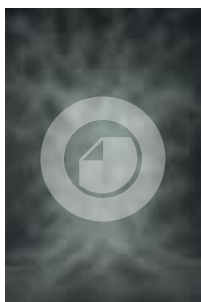

Ref: S208

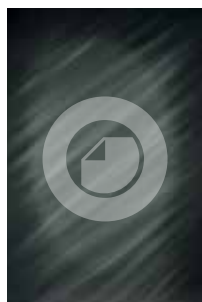

Ref: S209



serie400



Ref: S401



Ref: S402

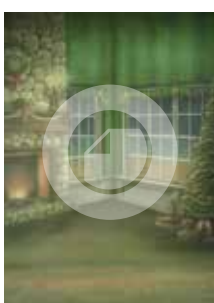

Ref: S403



Ref: S404



Ref: S405



Ref: S406



Ref: S407

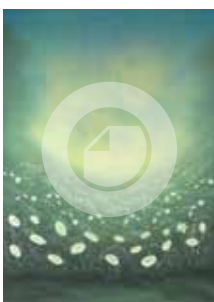

Ref: S408



Ref: S409



Ref: S410



Ref: S411



serie3D



Ref: 1499



Ref: 1502



Ref: 1498



Ref: 1500



Ref: 1501

serie3D











Telas translúcidas / Translucent backgrounds

Las telas translúcidas y muy suaves son un complemento ideal para crear ambientes suaves. Medida standard: 400x700cm.

The translucent and very soft drops are an ideal complement to create soft environments. Standard size: 400x700cm.



- | | | | |
|---|-----------------------------|---|------------------------------|
|  | MOD. 901 - Blanco / White |  | MOD. 905 - Amarillo / Yellow |
|  | MOD. 902 - Verde / Green |  | MOD. 906 - Azul / Blue |
|  | MOD. 903 - Violeta / Violet |  | MOD. 907 - Rosa / Pink |
|  | MOD. 904 - Rojo / Red |  | MOD. 908 - Beige / Beig |

Discos

Todos nuestros fondos podrán fabricarse también en la medida 150x200, pudiendo servirse en formato disco, montado en barra de aluminio o montado en expositor.

All our backgrounds can be manufactured on 150x200, and delivered as collapsible, mounted on an aluminium bar or mounted on roll screen.



Fondos de Papel / Paper backgrounds

Medidas: A1 (2,72x11m), A2 (1,36x11m) y B3 (3,60x30m)

Sizes: A1 (2,72x11m), A2 (1,36x11m) y B3 (3,60x30m)

A1/A2/B3 129 Super White	A1/A2 090 Soft Gray	A1/A2 110 Ermin Gray	A1/A2 102 Blu Gray	A1/A2 153 Photographers Gray	A1/A2 127 Silver Gray	A1/A2 123 Pursuit Gray	A1/A2 119 Plaza Gray	A1/A2 150 Steel Gray	A1/A2 170 Stone Gray
A1/A2 112 Graystone	A1/A2/B3 159 Storm Gray	A1/A2 109 Dove Gray	A1/A2 172 Dark Gray	A1/A2 131 Thunder Gray	A1/A2/B3 101 Black	A1/A2 115 Misti Blue	A1/A2 100 Alaska Blue	A1/A2 173 Cortez Blue	A1/A2 103 Blue Heaven
A1/A2 125 Regal Blue	A1/A2 161 Patriot Blue	A1/A2 136 Foto Blue	A1/A2 126 Regatta Blue	A1/A2 108 Deep Blue	A1/A2 165 Aqua	A1/A2 174 Spring Green	A1/A2 157 Teal	A1/A2/B3 132 Veri Green	A1/A2 162 Foto Green
A1/A2 137 Jade	A1/A2 128 Straw	A1/A2 107 Daf-Fo-Dil	A1/A2 169 Marigold	A1/A2 138 Sunflower	A1/A2 152 Tangerine	A1/A2 106 Creme	A1/A2 155 Ivory	A1/A2 121 Pongee	A1/A2 116 Natural
A1/A2 113 Hickory	A1/A2 117 Pastel Pink	A1/A2 163 Hot Pink	A1/A2 111 Flametone	A1/A2 139 Terracotta	A1/A2 124 Red	A1/A2 156 Ruby	A1/A2 133 Violet	A1/A2 154 Purple	

Serie 1600

Fondos rígidos de un color montados en núcleo de aluminio (Consultar medidas en la primera página)

A rigid funds color on aluminum core mounted (See sizes on the first page)

1638	1651	1604	1613	1625	1616	1653	1624	1657	1607
Chroma Key	1608	1603	1637	1606	1600	1632	1615	1659	1612
Chroma Key	1618	1626	1661	1641	1652	1621	1627	1631	1602
1605	1630	1658	1629	1620	1654	1617	1647	1646	1635

Fondos de Vinilo / Vinyl backgrounds

Montados en núcleo de aluminio, con superficie antirreflejos y fácil lavado (Medidas: 1,52x2,13m y 2,70x6m)

Mounted on aluminum core. With anti-reflective surface and easy cleaning (Sizes: 1,52x2,13m y 2,70x6m)

Vinilo White	Vinilo Gray	Vinilo Black	Vinilo Green
--------------	-------------	--------------	--------------



Portafondos portátil

Soporte portátil para fondos, compuesto de 2 pies, 2 barras transversales con cadena de plástico y funda de transporte.

Portable background support stand. The system consists of 2 support stands, 2 crossbar with plastic chain and a carry bag.

serie400 **vintage**

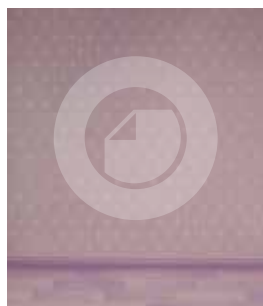

Ref: R406

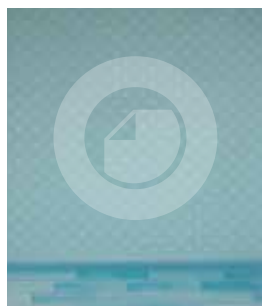

Ref: R407

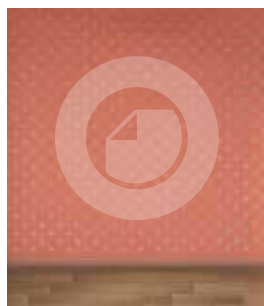

Ref: R410

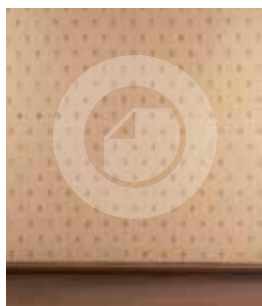

Ref: R416

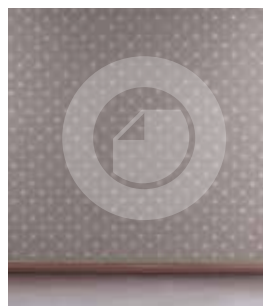

Ref: R418



Ref: R408

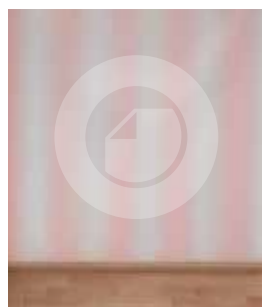

Ref: R411



Ref: R412

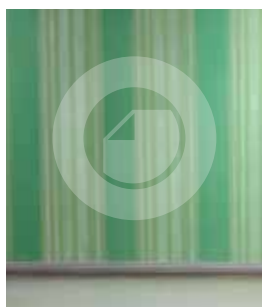

Ref: R419

serie400 **vintage classic**

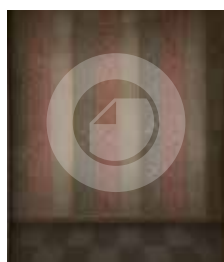

Ref: R402

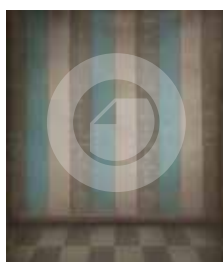

Ref: R403



Ref: R409



Ref: R405

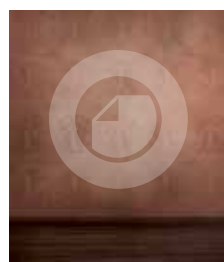

Ref: R404

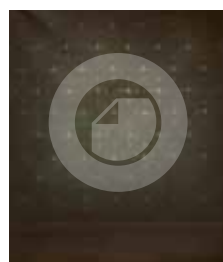

Ref: R401

serie400 **tradicional**

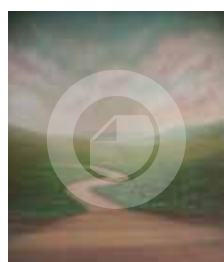

Ref: R423



Ref: R427

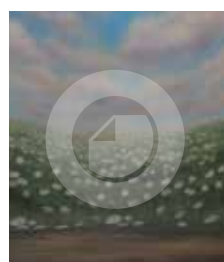

Ref: R415

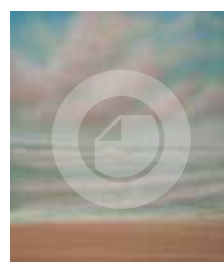

Ref: R413



Ref: R417

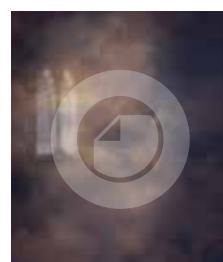

Ref: R428

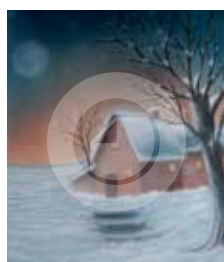

Ref: R420

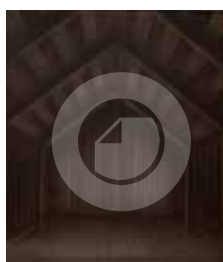

Ref: R414

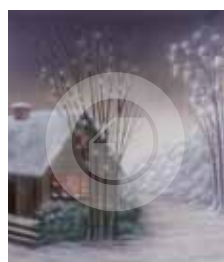

Ref: R421

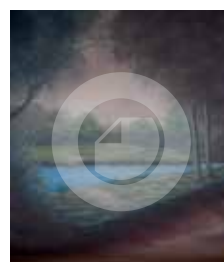

Ref: R426

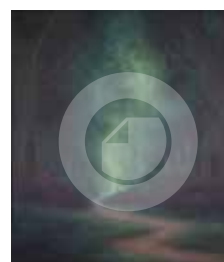

Ref: R424

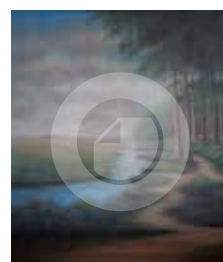

Ref: R425

serie200



Ref: R201



Ref: R202

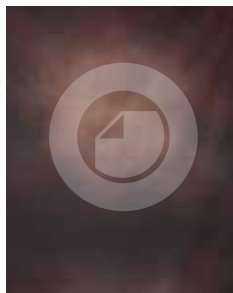

Ref: R203

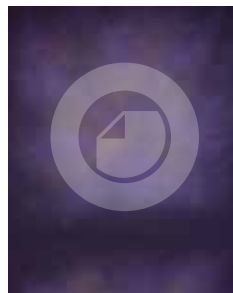

Ref: R204



Ref: R205

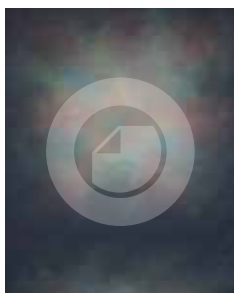

Ref: R206

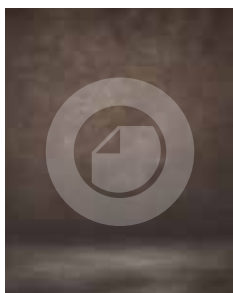

Ref: R207

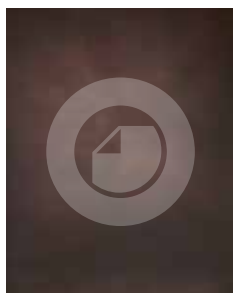

Ref: R208

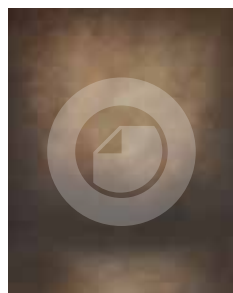

Ref: R209



Ref: R210

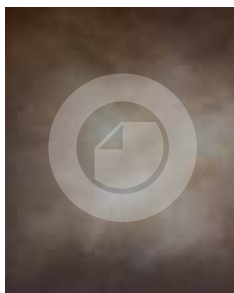

Ref: R211



Ref: R212



Ref: R213

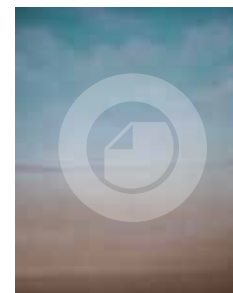

Ref: R214

serie3D



Ref: 1492A

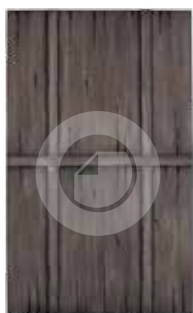

Ref: 1492B



Ref: 1493A

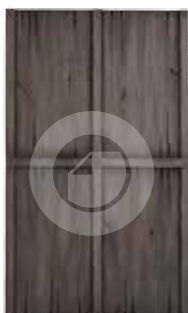

Ref: 1493B

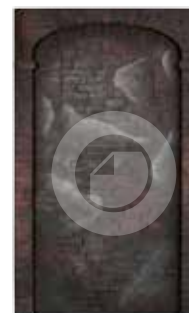

Ref: 1494A

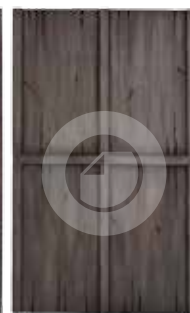

Ref: 1494B



Ref: 1495A



Ref: 1495B



Ref: 1496A



Ref: 1496B



Ref: 1497A



Ref: 1497B



Sistema sencillo y eficaz, de fácil manejo y montaje

Características:

- Motores fuertes con dos velocidades que permiten el uso de fondos tanto de lienzo como de papel.
- Control remoto por infrarrojos.
- Los fondos pueden ser cambiados con facilidad ya que no se tienen que desmontar ninguna parte del sistema.

Features:

- Strong drivers with two speeds that allow you to use canvas and paper backgrounds.
- Advanced IR remote control up to 10 backgrounds.
- Very easy to install and operate.



Soporte-4
Holder - 4



Soporte-6
Holder - 6



Soporte-10
Holder - 10

Juego Soporte para 6 o 3 fondos en línea Expander Manual

Set of holders for 6 or 3 backgrounds on a row
Manual expander

Espejo flexible Flexible mirror



Nuevas cajas de luz continua LED

New LED boxes

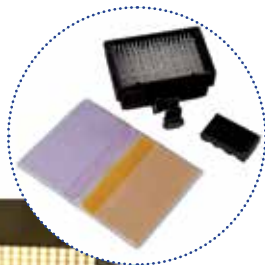

Funciona directo a luz o con batería
Connect with A/C power or with battery

LD1200
Con potenciómetro para variar la temperatura de color gradualmente de 3200K a 5600K

LD160
Iluminación LM: 780 Lm
Iluminación Lux: 1m: 900 lux
2m: 240 lux
3m: 120 lux
4m: 70 lux
Temperatura de color: 5600k / 3200k
Tamaño: 141x62x150 mm
Peso: 245 gr

LD900
Iluminación LM: 5535 Lm
Iluminación Lux: 1m: 8850 lux
2m: 2600 lux
3m: 1280 lux
4m: 650 lux
Temperatura de color: 5600k / 3200k
Tamaño: 460x52x450 mm
Peso: 2520 gr

LD1200
Iluminación LM: 7380 Lm
Iluminación Lux: 1m: 11800 lux
2m: 3600 lux
3m: 1600 lux
4m: 860 lux
Temperatura de color: 5600k / 3200k
Tamaño: 460x52x450 mm
Peso: 2520 gr

Todos los equipos llevan potenciómetro

Paneles para reflejar o restar iluminación

Panels to reflect or subtract lighting



Ref: 1097



Paneles modulares, pintados en blanco por la cara interior para reflejar la luz y en negro mate por la exterior para restar iluminación según las necesidades de la fotografía.

Están realizados en porexpan y recubiertos por una fina lámina de madera y, dotados de gran ligereza y resistencia.

Modular panels, white painted on the inner surface to reflect light and matt black on the outside to subtract illumination according to the needs of the picture.

Panels are made of porexpan and covered with a thin slide of wood, providing great lightness and restance.



Ref: 1108



Ref: 1109



Ref: 1104



Ref: 1110B



Ref: 1110 M



Ref: 1103



Ref: 1111



Ref: 1112



Ref: 1113



Ref: 1114

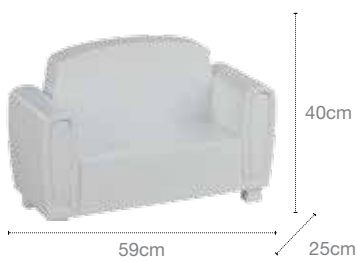

Ref: 1115



Ref: 1116



Ref: 1117



Ref: 1118



Ref: 1107R



Ref: 1107A



Ref: 1105A



Ref: 1105R



Ref: 1106A, 1106P, 1106R



Ref: 1119



Ref: 1120



Ref: 1121



Ref: 1122



Ref: 1123



Ref: 1102



Ref: 630



Ref: 668 / 669





Juego camisones
Ref: 829



Juego de sombrillas
Ref: 680

Ref: Paloma

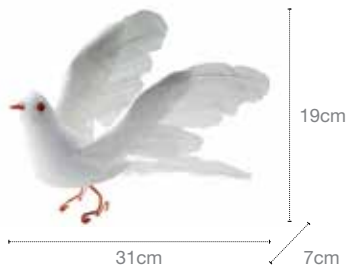

Ref: DF090



Ref: 771

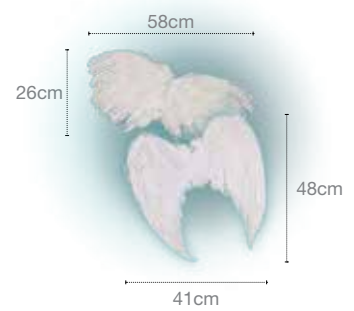

Modelo: 1045



Modelo: 1044

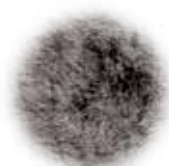

Modelo: 1046

Telas peludas

Ref: 1124



Ref: 1125



Ref: 1126



Ref: 1127



Ref: 1128



Ref: 1129



Ref: 1131



Baby poses

Ref. 992



Ref. 993



Ref: 1133



Ref: 1134



Ref: 1136



Ref: 1137



Ref: 1139



Ref: 1140



Ref: 1141



Ref: 1142



Ref: 629



Ref: 1149



Ref: 1150



Ref: 1070



El artículo 629 se entrega en una caja que representa un estuche de madera.



Ref: 1101

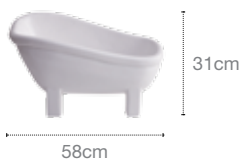

Ref: 1081



Ref: 1051



Ref: 1068



Ref: 1072



Ref: 1071



Ref: 1069





Ref. 1092



Ref. DF047
Gorro tarta azul



Ref. DF046
Gorro tarta rosa



Ref. DF018
Gorro cumpleaños azul



Ref. DF020
Gorro cumpleaños rosa



Ref. DF073



Ref. DF075



Ref. DF074



Ref: DF033



● Ref. 1065

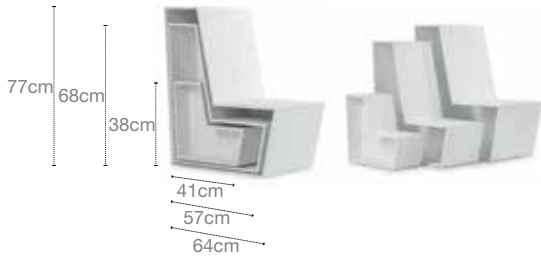

● Ref. 1066

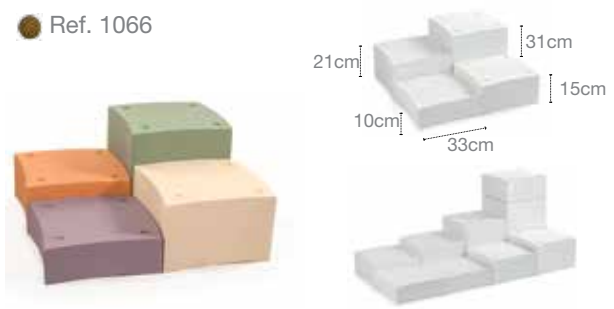

● Ref. 1074 ● Ref. 1075



● Ref. 1076



● Ref. 1073



● Ref. 1100

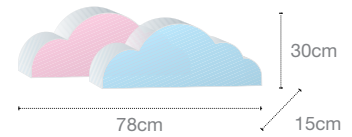

● Ref. 1086

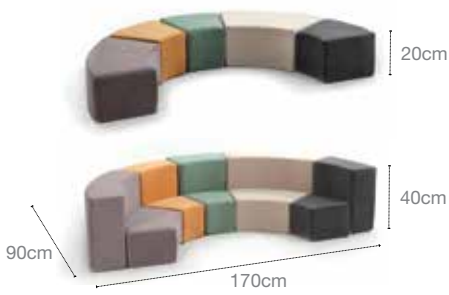

● Ref. A1079



● Ref. 1087



● Ref. 1088



● Ref. 1090

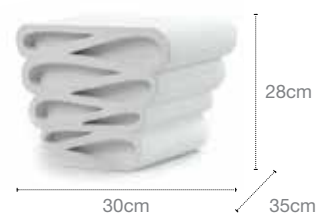

● Ref: 855

● Ref: 856



● Ref: B988

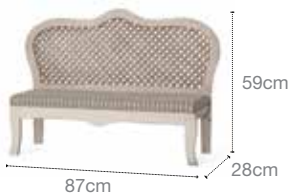

● Ref: B1015



● Ref: B1019



● Ref: B1008



● Ref: B982



● Ref: A1015



● Ref: R1019



● Ref: 1008





- Acabados
- B
 - M
 - R
 - A
- Tapizados
- (White circle)
 - (Black circle)
 - (Purple circle)
 - (Grey circle)

Ref: R1030



Ref: 1031



Tutú Rojo
Ref. DF038S

Calcetines Bailarina
Ref. DF041

Tutú Rosa
Ref. DF0039S

Cubrepañal tul rosa
Ref. DF034

Tutú Rosa
Ref. DF039L

Tutú Blanco
Ref. DF050L



Conjunto tutú lila
+ diadema Ref. DF037

Conjunto tutú
+ diadema Ref. DF035

Conjunto tutú rosa
+W diadema Ref. DF036

Juego de tres gorros
Ref. DF048



Conjunto gorro + balón
Ref. DF040

Gorro lana rojo
Ref. DF052

Pack alas de ángel
Ref. DF072

Turbante rosa
Ref. DF051

Turbante encaje
Ref. DF068



Juego de cubrepañales
Ref. DF042



Turbante rosa-amarillo
Ref. DF061



Turbante multicolor
Ref. DF058



Turbante flor rosa
Ref. DF057



Turbante 1 flor (fino)
DF065



Turbante 1 flor (grosso)
DF066



Turbante 2 flores beige
DF060



Turbante 2 flores blancas
DF062



Turbante encaje
DF067



Ref. 846



Conjunto gorros conejito
Ref. DF032



Cubrebebe Ref. DF071



Pack 3 sábanas de cuna
cuadros
Ref. DF053



Pack 3 sábanas de cuna
encaje
Ref. DF054



Ref: DF080



Ref: DF081



Ref: DF082



Ref: DF083



Ref: DF084



Ref: DF085



Ref: DF086



Ref: DF093



Ref: DF092



Ref: DF094



Ref: DF095





Ref: DF076



Ref: DF087



Ref: DF088



Ref: DF089 (pack de 3 unidades)



Ref: DF091



Ref: DF096



Ref: 1156



Ref: 1157

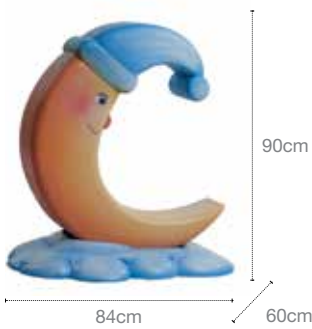

Ref: 1158



Ref: 1159



Ref: R1153



Ref: V1153



Ref: 1154



Ref: 1161



Ref: 1162



Ref: 1160





Ref: 1155



Ref: 1165



Ref: 1163



Ref: 1164



Ref: 1179



Ref: 1170



Ref: 1171



Ref: 1172



Ref: 1173



Ref: 1167



Ref: 1168



Ref: 1169



Ref: M1201 / B1201



Ref: 1188



Ref: 1174

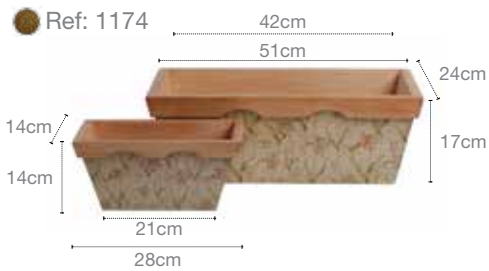

Ref: 1180



Ref: 1183



Ref: 1175



Mismas medidas Ref. 1174

Ref: 1181



Ref: 1184



Ref: 1176



Mismas medidas Ref. 1174

Ref: 1182



Ref: 1185



Ref: 1177

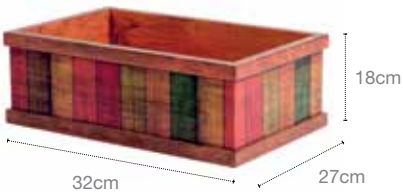

Ref: 1186



Ref: 1189



Ref: 1178



Ref: 1187



Ref: 1190



Ref: 1191



Ref: 1192



Ref: 1193



Ref: 1198



Ref: 1204



Ref: 1205



Ref: 1194



Ref: 1195

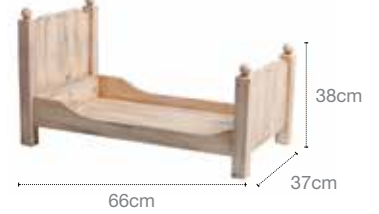

Ref: 1196

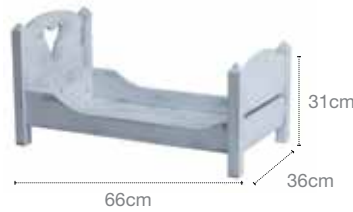

Ref: 1197



Ref: M1200 / B1200



Ref: M1199 / B1199



Ref: M1202/B1202



Ref: 1206

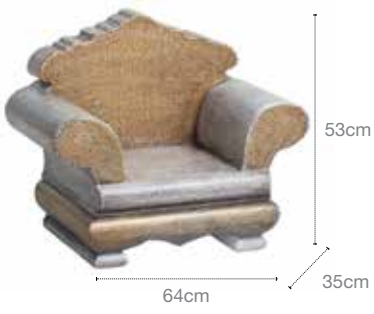

Ref: 1207



Ref: 1208



Ref: 1209

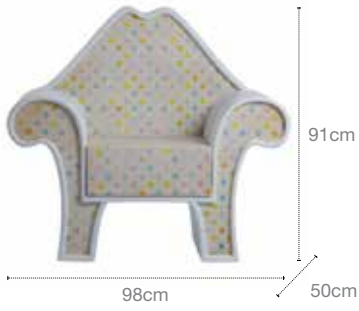

Ref: 1210



Ref: R1211



Ref: A1211



Ref: M1210



Ref: V1210



Ref: R1210



Ref: B1210



Ref: 1213





Ref: 1215



Ref: 1216



Ref: 1217



Ref: 1218



Ref: 1219

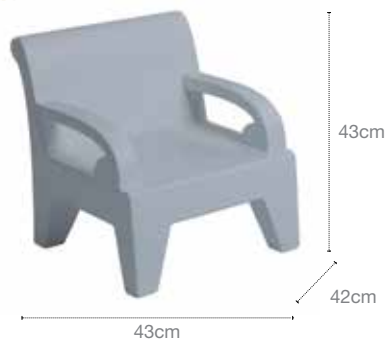

Ref: 1227



Ref: 1221



Ref: 628



Ref: M628



Ref: 1214



Ref: 1224



Ref: 1225



Kit riel completo



Ref: 500

Esponjas mágicas para limpiar fondos

Magic sponges to clean funds

Esponjas especiales para limpiar fondos de lienzo o de vinilo. Se venden sueltas o en paquetes de cinco. Medidas: 15x10x5 cm

Special sponges to clean canvas or vinyl funds. Loose or in packs of five. Size: 15x10x5 cm



Ref: Esponja

Laminadora en caliente

Warm laminating machine

Laminadora automática en caliente de 110 cm de ancho de velocidad y presión regulable.

High quality model warm laminating with 110cm width.



Ref: G1020

Laminado con adhesivo y protección UV

Ref: 25
SUPER BRILLO

Ref: 6
MATE LISO

Ref: 5
ACABADO PIEL

Ref: 4
ACABADO ARENA

Ref: 2
ACABADO ANTICOPI

Ref: DC
ADHESIVO DOBLE





Ref: ENA01

Prensa manual fabricada en acero inoxidable. La presión y la altura son ajustables de forma manual. La máxima presión que puede alcanzar son 2 toneladas.

Área de trabajo: 460x350mm, Peso: 52kg

Manual nipping machine, It is made in stainless steel, height and pressure can be adjusted by hand wheel. Most pressure can reach up to two ton.

Flatten area: 460x350mm, Weight: 52kg.

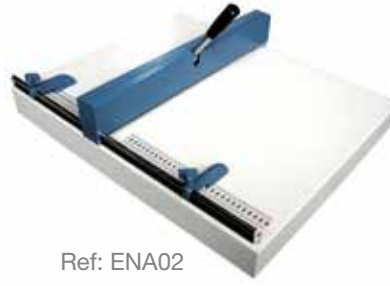

Ref: ENA02

Hendidora manual, realiza un hendidado de 460mm. Fácil de utilizar, con una escala para indicar la posición del hendidado. Tiene dos frenos para realizar múltiples hendidados.

Dimensiones: 600x500x180, Peso: 13kg

Manual Creasing machine, it creases up to 460mm. Easy to use, it has a scale to show the position of the crease.

Flatten area: 600x500x180mm, Weight: 13kg.



Ref: ENA06

Máquina encoladora, encola libros de hasta 460x325mm, tiene un aplicador de cola electrónico para un encolado consistente y duradero. También permite mover el papel desde el freno hasta tres tamaños predefinidos. Formatos A3, A4 o A5.

Binding Machine, binds books up to 460 x 325mm; it features electronic glue application for consistent binding on longer runs. It is also possible to move the paper stopper to one of the three predefined fastening places for A3, A4 or A5 formats.

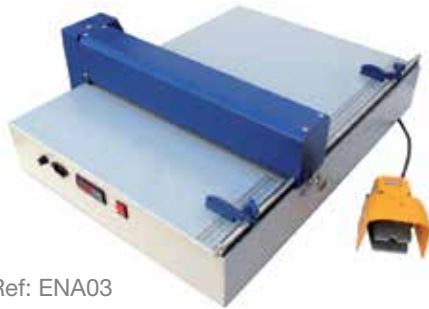

Ref: ENA03

Hendidora eléctrica diseñada para calentar el hendidado, la temperatura es ajustable hasta 99°C. Además de ser una hendidadora eléctrica, es ideal para hender papel que ha sido laminado ya que elimina el efecto de despegado del laminado en el hendidado.

Máximo hendidado 520mm, peso 35kg, dimensiones: 800x630x230mm, potencia eléctrica: 220v/110v

Electric Creasing Machine, designed for heating type, heating temperature is limitless adjustable within 99°C. Besides being an electric creasing machine, it has extremely good effect upon dealing with the heat-laminated paper, and also can avoid the phenomenon of striping and edge bursting to the greatest extent.

Max. crease 520mm, weight 35kg, size: 800x630x230mm, electrical power: 220v/110v



Ref: ENA05

Maquina para Hacer Tapas diseñada como una mesa compacta con guía lateral, el tamaño de las tapas realizadas puede llegar hasta el formato A3.

Tamaño de trabajo: Máximo grosor del cartón: 0,5-6mm, dimensión: 1120x600x270mm, peso: 39Kg, potencia eléctrica (opcional): 220v/110v

Hard cover Maker, Suitable for making hard cover books, CD and DVD boxes, Designed for compact table-top unit, with side guide. The hard covers can be up to A3 size.

Size: 1120x600x270mm, weight: 39kg, (optional) electrical power: 220v/110v



Cizalla profesional de rodillo: Rotatrim es la cizalla perfecta para el profesional. Cuenta con dos raíles de guía gemelos en acero cromado, cuchilla de corte autoafilable de acero de tungsteno y base de melamina cuadrada con indicaciones de formato. La capacidad de corte es de hasta 3mm y su longitud abarca desde DIN-A4 hasta DIN-A0+.

Rotatrim is Originally designed to meet the exacting requirements of the professional photographer. Some of the benefits of the Professional series are, robustness and reliability for a rotary trimmer, offering an extremely long duty life, Solid laminated basesboard, Precision side rule and cursor, Hand-finished tungsten steel flat and rotary blades offer unrivalled accuracy and longevity.

The cut capacity is up to 3mm and the cut length is from 305mm up to 1374mm.

Encuadernadora manual o neumática. Encuadernaciones digitales de hasta 40x50cm, funciona con compresor de aire no incluido.

Manual or pneumatic alligment machine, binds professional digital portraits up to 40x50cm, it works with air compressor not included.

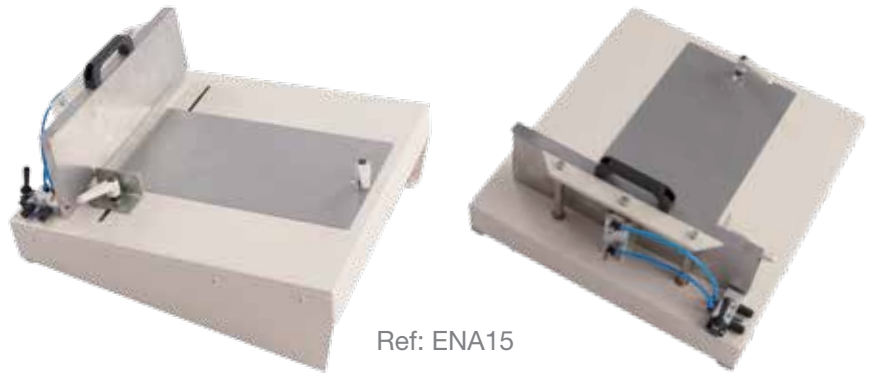

Ref: ENA15



Hendidora 42
Creasing machine 42

Ref: 4205

Hendidora para formato A3 y peso máximo de papel de 400g/m2. Realiza hendidos longitudinales en las fotografías para doblarlas fácilmente. Ancho máximo de trabajo 435mm, ancho de hendidado, 1,2/1,8mm

Creasing Machine with a maximum working size of 435mm and maximum weight of paper 400g/m2. This machine makes creases on the pictures so they can be folded easily. The width of the crease is 1,2/1,8mm.

Guillotina con luz de corte de 430mm, altura de corte 40mm, pisón acción rápida, cuchilla de gran calidad de "acero Solingen".

This guillotine width is 430mm, it can cut up to 40mm height at the same time.

Guillotina eléctrica de 450mm de boca. Permite el corte de 400 hojas de 70g. por vez. La profundidad de corte es también de 450 mm con regulación de posicionamiento manual. Corte mínimo: 50mm. Posee el sistema de presión automática al descender junto con la cuchilla de corte.

La guillotina eléctrica indica la señalización de corte con un haz de luz láser. Posee sistemas de seguridad que consiste en la protección del operador, conformado por una doble botonera. Al no utilizar los dos botones de accionamiento no permite descender la cuchilla, en simultáneo con una tapa de acrílico que también detiene el funcionamiento de la cuchilla hasta que la misma no esté cerrada (*microswitch*).

Dimensiones: 1020 (altura) x 760 (ancho) x 670mm (fondo). Peso: 95Kg. Modelo en 220 Voltios.

Electric guillotine with a 450mm mouth. Cuts up 400hojas than once. Automatic pressure system. Includes laser light and security systems to protect the operator. The keypad lock prevents the blade down, acrylic cover stops operation of the blade.

Dimensions: 1020cm high x 760cm wide and 670mm background. Weight: 95Kg. Electrical power: 220v.



Ref: ENA16



Ref: ENA11
Ref: ENA12

Guillotina con cuchilla electrico-mecánica, calibración con manivela para un ajuste fino de la trasera, indicador de línea de corte óptico y lamina de corte de acero de alta calidad.

Guillotine with electromechanical drive of blade, hand crank with calibration ring for fine adjustment of back gauge, optical cutting line indicator, blade from high quality steel, complete with stand and strage shelf.

ENA011

ancho de corte / *cutting length: 430mm*
 profundidad de corte / *insertion depth: 430mm*
 altura de corte / *cutting height: 40mm*
 dimensiones / *dimensions: 660x750x1150mm*

ENA012

ancho de corte / *cutting length: 475mm*
 profundidad de corte / *insertion depth: 455mm*
 altura de corte / *cutting height: 60mm*
 dimensiones / *dimensions: 760x850x1250mm*



Hojas del montaje del Fotolibro

Hojas adhesivas doble cara, blancas y negras, disponibles en 200mic y 500mic.



Ref: FOAMCUT152

Guillotina para foam 152cm: La guillotina para foam ofrece una calidad y durabilidad únicas en el mercado. Fácil de manejar, ideal para cortar materiales como el PVC y el cartón pluma, también corta con facilidad materiales como películas o papel. Anchura de corte: 152cm

The Trimmer offers many unique features and durability that make it the best value trimmer/cutter available. Capable of handling your most demanding trimming needs, the Total Trimmer is the versatile work-horse trimmer you have been looking for. Ideal for trimming difficult materials like PVC foamboard and vinyl, it also easily cuts common materials such as films and paper. Working with: 152cm





Foam blanco con aluminio

White foam with aluminum

10mm

5mm

Tamaño de la hoja / Sheet Size: 105x152 y 122x244

Foam negro

Black foam

10mm (10 hojas por caja / sheets per box)

5mm (20 hojas por caja / sheets per box)

Foam Blanco

White foam

10mm (10hojas por caja / sheets per box)

5mm (20 hojas por caja / sheets per box)

3mm (30 hojas por caja / sheets per box)

Tamaño de la hoja / Sheet Size: 102x152



Cinta adhesiva doble cara ideal para el pegado de fotos y disponible en distintos tamaños.

Tesa:

12mmx50m

19mmx50m

25mmx50m

50mmx50m

Scotch:

12mmx44m

También disponible la máquina aplicadora para la cinta scotch.



Colgadores para foam. Colgador metálico con anclaje para paneles foam / Hangers foam. Hanger anchor metal foam panels.



Colgadores metálicos con bisagra

para paneles de foam / Hinged metal hangers foam panels.



Foam cutter, útil de corte para el foam / Cutter designed especially for cutting foamboard.



Tapete de corte útil para trabajar con cutter sin dañar la superficie de trabajo. Tamaño 60x90.

Cutting Mat provide a long lasting surface that can be cut without showing marks or cutting lines.

Ref. 811 verde / green

Ref. 810 Transparente / Transparent



Regla diseñada para el corte con cutter / Rule designed for cutting with cutter



Bastidores en diferentes tamaños
Frame for canvas in different sizes



- Barniz** para proteger los lienzos / *Varnish to protect canvas*
- Rodillo y cubeta** / *Tray and roller*
- Pinza** montaje lienzos / *Clamp for canvas mounting*
- Spray Hahnemühle** para proteger fotografías
The Hahnemühle Protective Spray

Medidas bastidores
Frame sizes

- 30x30cm 50x50cm
- 30x40cm 50x60cm
- 40x40cm 60x60cm
- 40x50cm 50x70cm
- 100x100cm

Cubiertas para álbums con diferentes diseños y calidades

Covers for albums with different qualities & designs

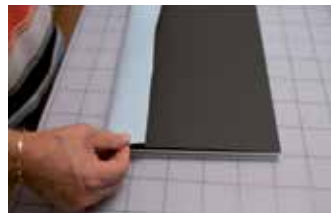

Crea tus propias Fotoportadas
o diseña un álbum de gran calidad

Lisos / Smooth



Diseño: Roma
Acabado: 08



Diseño: Roma
Acabado: 19



Diseño: Roma
Acabado: 24



Diseño: Roma
Acabado: 30



Diseño para
Fotoportada
Acabado de traseira: 08

Combinados / Combined



Diseño: Viena
Acabado: 16 + 08



Diseño: Viena
Acabado: 09 + 12



Diseño: Oslo
Acabado: 09 + 10

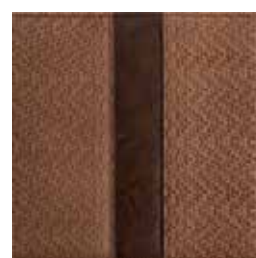

Diseño: Amsterdam
Acabado: 25 + 23



Diseño: Madrid
Acabado: 21 + 23 + 22

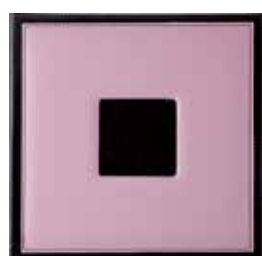

Diseño: Milan
Acabado: 09 + 05



Diseño: Milan
Acabado: 20 + 06



Diseño: Zurich
Acabado: 01 + 04



Diseño: London
Acabado: 01 + 05

Vertical



Diseño: Roma
Acabado: 12



Diseño: Roma
Acabado: 28

Boda / Wedding



Diseño: Berlín
Acabado: 11 + 09

Diseños / Designs

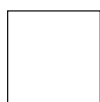

Roma

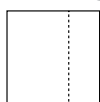

Viena

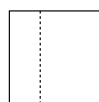

Berlín

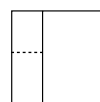

Madrid

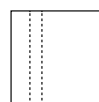

Valencia

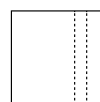

Oslo

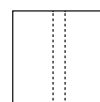

Amsterdam

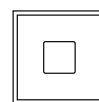

Milán

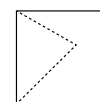

Dublín

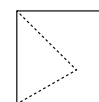

London

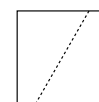

Zurich



Fotoportada

Acabados / Materials

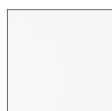

01



02



03



04



05



06



07



08



09



10



11

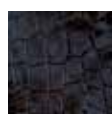

12



13



14



15



16



17



18



19



20

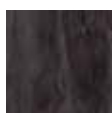

21



22



23



24



25



26



27



28



29



30



33



34



37

Diseños y tamaños personalizables /
Customizable sizes and designs

Acabados nuevos

New Materials



112



114



116

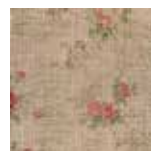

118



119



120



122

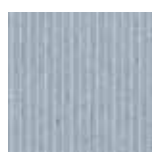

123

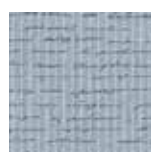

130



131

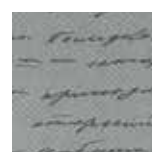

132



Fotoimanes recordatorios

Diferentes tamaños para tus fotografías



Cajas MALI en distintos tamaños y acabados

Boxes for pictures in different sizes

Perfectas para presentar álbumes, paspartús, usb y cd.
Combinables con los paspartús.

A perfect way for presenting your pictures on albums, paspartu, usb or cd.

Caja MALI
Acabado 114
Acabado 115



Caja MALI
Acabado 124
Acabado 131

Caja MALI
Acabado 119
Acabado 118



Caja MALI
Acabado 116

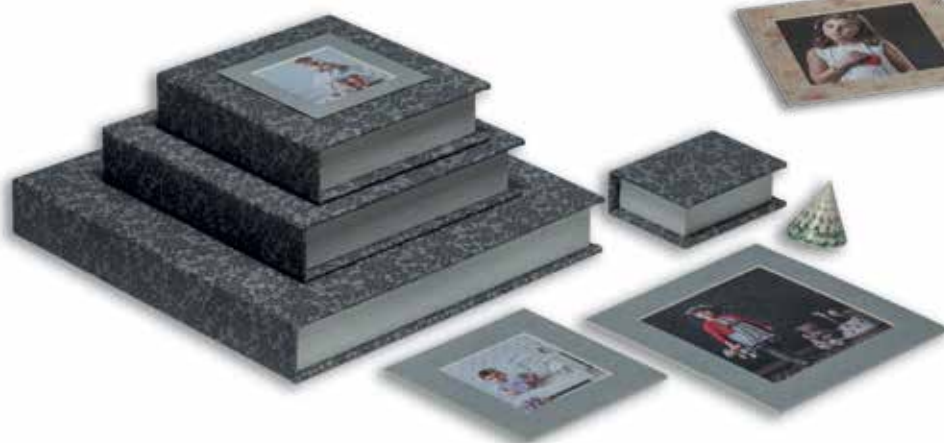

Caja MALI
Acabado 132



Caja MALI
Acabado 122



Caja MALI
Acabado 130
Acabado 123



Caja MALI
Acabado 125
Acabado 126



Cajas MALI en distintos tamaños y acabados

Boxes for pictures in different sizes

Cajas PERSONALIZADAS



Cajas DAKAR en distintos tamaños y acabados

Boxes for pictures in different sizes

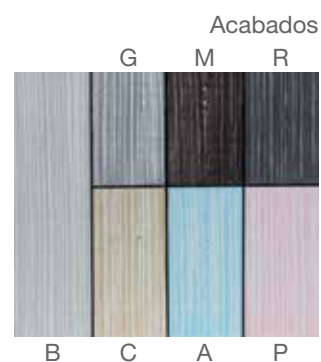

Cajas MALI para automontado en distintos tamaños

Boxes Mali self mounted, available on different sizes

Cajas preparadas para autoacabado, realizadas en madera y cartón.

Boxes prepared to be self mounted, made on wooden and cardboard.

Tamaño: 20x25cm
Size: 25x25cm
25x30cm

● Artículo fabricado en madera
Made of wood



Bolsas / Bags



Mod. Volga



Mod. Volga



Mod. Rhin



Mod. Rhin

Fotocalendarios

Paspartús especial para calendarios

Special mats calendars



Tamaños
fotocalendarios:

Size:

Grande

15,5x15,5cm

Pequeño horizontal

10x10,5cm

Pequeño vertical

10x10cm

Paspartús cortados en bisel de diferentes colores y tamaños

Matboard, bevel cut in different sizes and colors

Colores y texturas / Colors and textures



Para el pedido de paspartús deberá indicarse el modelo, el color y el tamaño tanto exterior del paspartús como de la foto a presentar.

Se podrá pedir el paspartús sin cubierta, con cubierta vegetal, cubierta de cartulina, sin trasera, con la trasera pegada o, por separado sin pegar.

To order Mats you have you choose the reference number, the colour and the size of the picture you are going to show and the exterior size of the Mat.

Tamaños exteriores:

Outside size:

- 15x20cm
- 18x24cm
- 20x25cm
- 25x30cm

Los colores pueden variar levemente debido a la calidad de impresión del catálogo / The colors shown are approximate only

Paspartús con cubiertas

A elegir entre cubierta vegetal, cartulina o sin cubierta

You can choose between indoor vegetal, cartolina cover or without cover.

Mod.10
Color E
Sin cubierta



Mod.10
Color E
Cubierta cartulina



Mod.10
Color E
Cubierta vegetal

Paspartús-portafotos

Doble paspartús cortado en bisel

Double mats, bevelled



Las patas se venden en paquetes de 100 y de 25 unidades.
Stands are sold in packs of 100 and packs of 25.



Stilfondo sigue creciendo y dando soluciones a nuestros clientes. Con la creación de Fotostil estamos capacitados para ofrecer al fotógrafo todo lo necesario para la vida digital: impresoras de gran formato, ordenadores, consumibles, soporte técnico, etc. Además, Fotostil ha heredado la tradición formadora que siempre ha caracterizado a Stilfondo, ofreciendo a nuestros clientes un amplio abanico de cursos impartidos por profesionales altamente cualificados.

Established in 1987, Stilfondo's growth is representative of the solutions on offer our customers. The creation of fotostil enables Stilfondo to enhance our product range and offer the photographer all the necessary tools required to bring life to Digital Photography. These include but are not limited to large Format Printers, computers, supplies, Technical Support, etc . Stilfondo's established tradition of in-house training means we can also offer clients a wide range of courses presented by highly qualified professionals.

Todo el mundo Apple a tu alcance
Solo tienes que pedirlo



Nuevo Mac Pro

A veces, para dar un salto hacia adelante tienes que cambiar de dirección .

La forma más eficaz y revolucionaria de desarrollar gráficos, almacenamiento, procesador, memoria y posibilidades de ampliación. Todos los componentes del nuevo Mac Pro se han optimizado pensando en el rendimiento para poder hacer las tareas más exigentes en nada de tiempo y sin interrupciones.

Sin duda, el nuevo Mac Pro es un ordenador profesional completamente nuevo. Algo que rompe con lo que conocemos hasta ahora. Te presentamos el futuro del ordenador profesional:



La tecnología gráfica es aun más potente para poder editar vídeo y renderizar efectos en segundo plano y aún seguirá sobrando potencia. Las unidades de estado sólido son las más veloces disponibles en un ordenador de mesa: podrás arrancar el equipo, iniciar Apps y hasta abrir archivos enormes en un abrir y cerrar de ojos.

El nuevo Mac Pro es capaz de concentrar una potencia sin precedentes en un tamaño muy reducido. Ningún ordenador tiene un diseño con estas características.

MacBook Pro

Gracias a su pantalla de Retina es el portátil con mayor resolución del mundo. Incorpora tecnología flash ultrarápida y el procesador más veloz para portátil. Todo ello en un diseño tremendamente fino y ligero, te lo ofrecemos en 13 o 15 pulgadas.

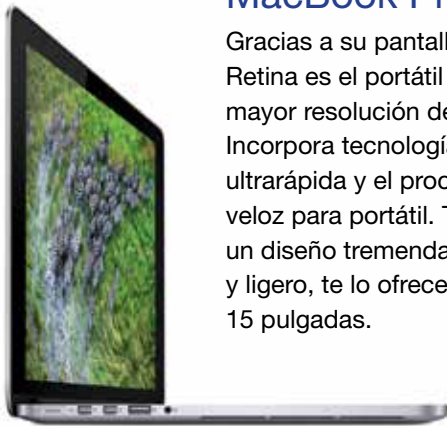

iMac

Ordenador todo-en-uno, una auténtica obra de ingeniería que destaca por su espectacular pantalla panorámica. Al reducir los reflejos en un 75% y uniendo el LCD a la cubierta de vidrio Apple ha conseguido mejorar una pantalla que de por sí ya era asombrosa. Lleva un procesador de cuatro núcleos, Thunderbolt superveloz y almacenamiento Fusion Drive.

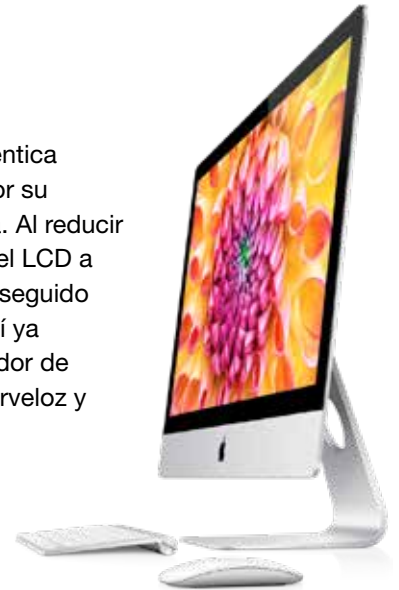

Mac Book Air

¡Dispone de hasta 12 horas de autonomía y aguanta hasta un mes en reposo! Gracias a los nuevos procesadores Intel Core de cuarta generación y a un montón de prestaciones tan prácticas como eficientes, podrás hacer más y durante más tiempo. Nunca tanta potencia había sido tan fácil de llevar a todas partes.



Mac mini

Se ocupa de todo pero no ocupa nada. El Mac mini tiene puertos de sobra para que conectes tus periféricos, como tu televisor de alta definición. Además, posee un procesador de cuatro núcleos que es hasta dos veces más rápido que el modelo anterior. Ofrece más potencia gráfica y un montón de espacio de almacenamiento. Con el Mac mini, tú decides.

Adobe® Creative Cloud

Todas las herramientas que adoras, totalmente reinventadas

Creative Cloud contiene todo lo que necesitas para experimentar como nunca antes. Si alguna vez has soñado con ampliar tu trabajo y crear sitios web, apps, vídeo y mucho más, ahora es el momento.

Adobe Photoshop dispone de decenas de funciones nuevas, incluida la herramienta de enfoque más avanzada disponible. Comparte tu trabajo directamente desde el programa, sincroniza tu configuración entre distintas máquinas y accede a funciones nuevas en cuanto estén disponibles.

Llega la versión de Illustrator más potente y conectada de todos los tiempos. La nueva herramienta “Retocar texto” te ofrece un mayor control del texto: mueve, cambia la escala y gira caracteres individuales con la certeza de que podrás cambiar o editar la fuente o el texto en cualquier momento.

Llega la compatibilidad con 64 bits en InDesign, la creación de códigos QR, mejores archivos EPUB, una interfaz de usuario más elegante y las herramientas para encontrar la fuente perfecta con más rapidez. Además, ahora puedes compartir tu trabajo directamente desde InDesign y mantener tu Suite actualizada en todo momento.

Dreamweaver trae nuevas funcionalidades de edición visuales entre las que se incluye el “Diseñador de CSS”. Mantente al día sobre los últimos estándares web, con actualizaciones continuas disponibles para que los abonados a Creative Cloud las puedan descargar.

¡Y esto sólo es el principio!



Adobe CC



Impresiones y pruebas asombrosas

Para atender las necesidades concretas de los entornos de pruebas y producción, así como de las aplicaciones de fotografía especializadas, la iPF6400 y la iPF8400 incorporan el nuevo sistema LUCIA EX de 12 tintas pigmentadas de Canon. El sistema de tintas pigmentadas LUCIA EX se combina con una tecnología de procesamiento de imágenes mejorada para obtener una amplia gama de colores, gradaciones suaves, un menor efecto metalizado y una gran resistencia a arañazos en las impresiones.

El sistema también ofrece unos negros más nítidos y suaves gradaciones en zonas oscuras, logrando una excepcional calidad de impresión para las aplicaciones de impresión fotográfica.

Las líneas y los textos más precisos, así como la excelente homogeneidad del color a lo largo de toda la página, permiten que la impresora funcione como un dispositivo de pruebas de extraordinaria precisión.

La iPF8400 te permitirá cumplir con todos tus plazos de entrega por ajustados que sean. Los depósitos de tinta “intercambiables en caliente” se pueden sustituir durante la impresión y su capacidad máxima de 700 ml permite lograr los mejores resultados.



CANON iPF6400



CANON iPF8400

EPSON®



EPSON Stylus Pro 7900
EPSON Stylus Pro 7890



EPSON Stylus Pro 9900
EPSON Stylus Pro 9890

Entra en una nueva y fascinante era en representación del color

Conseguirás una mayor diversidad de opciones de color con el nuevo juego de cartuchos Epson UltraChrome™ HDR (High Dynamic Range). Añadiendo naranja y verde se consigue una gama cromática mucho más amplia, para reproducir unos tonos verdes hiperrealistas, como en imágenes con hierba o naturaleza, crepúsculos más impactantes y unas tonalidades de piel tan suaves como las de un bebé. No se parece a nada que hayas visto antes.

Precisión y uniformidad asombrosas en todo el espectro cromático

Mediante una nueva y potente tecnología, la Stylus Pro 9900 selecciona la combinación óptima de color para expresar con la mayor precisión el color deseado. Esto significa una reducción de la gradación y la granulación y una mayor constancia del color bajo diferentes fuentes de luz.

Resultados de alta calidad, rápidos y fiables

La excepcional velocidad y calidad de la Stylus Pro 9900 se basa en la tecnología de inyección de tinta que establece nuevos límites en la creación de imágenes de calidad fotográfica. El cabezal de impresión Micro Piezo TFP, optimizado para la tinta Epson Ultrachrome HDR, tiene 360 inyectores por color de gran precisión, que producen imágenes increíblemente nítidas, sin granulado, a una velocidad ultrarrápida.

Una amplia gama de soportes y una mayor velocidad de corte

Elige cualquier tipo de soporte en rollo, incluyendo tela, lienzo y papel adhesivo. El manejo del papel nunca ha sido tan sencillo, y con la nueva cortadora giratoria de papel, se puede cortar una hoja entera suave y limpiamente en sólo dos segundos.



HP Designjet Z3200

Magníficas impresiones en color y en blanco y negro con calidad de exposición.

Impresiones con calidad expos de 200 años en suport. El sistema de 12 tintas HP Vivera, con un nuevo rojo ofrece una amplia gama cromática. El conjunto de tintas HP Quad-Black proporciona unos magníficos resultados en blanco y negro. El intensificador de satinado reduce el aspecto metálico.

Las tecnologías HP DreamColor ofrecen funciones sencillas de calibración y gestión de perfiles, y logran colores precisos y uniformes.

Consige colores precisos y uniformes con las sencillas tecnologías HP DreamColor. La herramienta HP Color Center mejorada y el espectrofotómetro integrado simplifican las tareas de gestión de perfiles y calibración. Crea, importa y exporta ajustes de papel fácilmente.

Permite un funcionamiento productivo y una gran eficacia de tinta.

Eleva tu eficacia operativa. La tinta y la tecnología de los cabezales de impresión originales de esta impresora de HP permiten realizar un mantenimiento preventivo que la mantendrá en perfecto estado de funcionamiento. Además es económica ya que utiliza un mínimo de tinta durante el mantenimiento rutinario.

wacom®

INTUOS®pro

Intuos pro

Diseñados para la creatividad: sencillamente, las herramientas perfectas. La novedosa tableta Wacom Intuos Pro te brinda la oportunidad de producir resultados profesionales. Al combinar las capacidades del lápiz de alta tecnología con intuitivos gestos de la función multitáctil, cuenta con las mejores características de precisión y control de los pinceles, lápices y rotuladores profesionales con un software profesional. Disponible en tres tamaños, ofrece una experiencia natural e intuitiva que potencia tu creatividad.



Intuos

Diseñada para la creatividad: la máxima expresión de la naturalidad desde la primera conexión.

Las innovadoras tabletas creativas de lápiz Wacom Intuos combinan el lápiz sensible a la presión y las capacidades de función multitáctil* en un dispositivo inteligente para ofrecer un modo más expresivo e intuitivo para trabajar con el ordenador. Diviértete desde el mismo primer momento e impulsa tus capacidades de creatividad, dibujo o edición de fotos.

Nunca ha sido tan fácil.



grandes marcas tabletas digitalizadoras Wacom

NEC

Rendimiento superior y calidad de imagen con una amplia serie de funciones innovadoras y conectividad mejorada. Nuevas funciones que incluyen ajuste automático a las condiciones de luz presentes y contenido de imagen, tiempo de reacción mejorado gracias a la tecnología OverDrive, funciones de apagado automático y un diseño totalmente ergonómico.



LACIE

La tecnología de retroiluminación de RGB-LED de capacidad insuperable del monitor LaCie produce colores primarios, rojos, verdes y azules más puros. Esto da como resultado una gama más amplia de colores vibrantes que, anteriormente, no se podía obtener mediante monitores LCD basados en CCFL. Cubre una amplia gama de colores que llega al 116% del estándar NTSC y al 114% del Adobe RGB (CIE 1976), ofreciendo una experiencia de color más fiel a la vida real que no se había conseguido hasta ahora. La tecnología de panel VA-LCD LaCie proporciona también negros oscuros, un contraste muy alto y ángulos de visión excelentes. Su corrección de gamma de 14 bits y estabilizador de retroiluminación ColorKeeper ofrecen una visualización suave de los gradientes y un rendimiento estable en el tiempo. El monitor LaCie viene con el software LaCie blue eye pro Proof Edition que incluye una prueba de certificación de pantalla desarrollada en colaboración con UGRA, el centro suizo de competencia para tecnología de impresión y medios. De esta manera, el monitor LaCie se presenta como la opción ideal para las aplicaciones más críticas en las que es necesario un color profesional.



EIZO®

LCDs capaces de satisfacer lo que las empresas demandan para un monitor, tienen marcos muy finos para el ahorro de espacio, alto contraste 1000:1 para las aplicaciones exhaustivas en texto, gran calidad de imagen y funciones de control de color, y sobre todo ofrecen comodidad a sus usuarios, ya que gracias a sus diferentes stands permiten ajustarlos en altura, giro, etc. lo que redundará en una correcta posición de trabajo. Pero sobre todo ofrecen Calidad de imagen.



Disponemos de una amplia gama de productos de almacenamiento de las mejores marcas.



- Discos duros internos
- Discos duros externos
- Almacenamiento en red
- Tarjetas de memoria
- Dockstation para discos



Colores exactos compatibles con las paletas de cualquier parte del mundo.

ColorChecker

Passport color checker

ColorChecker Passport es un producto único y completo para procesamiento de imágenes digitales desde su captura hasta la edición, pensado para todos los fotógrafos que buscan colores constantes y precisos sin excluir la flexibilidad creativa. Además, al utilizar ColorChecker Passport junto con las soluciones informáticas de Adobe® Imaging, usted obtendrá ventajas aún mayores. ColorChecker Passport contiene tres objetivos fotográficos en un estuche protector, de bolsillo, con posicionamiento autónomo que se adapta a cualquier escenario. Junto con el software incluido para calibración de cámaras, usted obtiene lo mejor en términos de funcionalidad, flexibilidad y portabilidad.

X-Rite i1Display Pro

Es la solución definitiva para los perfeccionistas creativos que exigen velocidad, opciones y flexibilidad para alcanzar la precisión del color.

Los perfeccionistas del color saben que una pantalla calibrada y perfilada es un elemento clave en cualquier flujo de trabajo digital eficiente. Nadie quiere dedicar tiempo a retocar imágenes en el monitor o sus vídeos para terminar descubriendo que la pantalla no mostraba correctamente los archivos digitales. Lo que vea en su monitor, dispositivo móvil o proyector debe coincidir con su archivo digital, o nunca conseguirá estar satisfecho con el resultado, por más tiempo que dedique a perfeccionarlo.





Pol. ind. nº 1, calle Moliners s/n
Tel. 96 245 51 30 Fax 96 240 15 32 - Apartado de Correos 55
46600 - ALZIRA (Valencia) España

www.stilfondo.com

info@stilfondo.com

25

VOLUMEN

